

hyperMILL® 5AXIS

Machining complex geometries with deep cavities, high steep walls and undercuts requires precisely defined milling areas and many different tool angles, which can be achieved without collisions using 5axis machining. Depending on the geometry and machine kinematics, the user can choose between 5axis machining with a fixed tool angle, automatic indexing or true simultaneous motion.

Strategies for cavity machining (Mold & Die)

hyperMILL® 5AXIS expands familiar 3D strategies to include 5axis positions. Thanks to the fully automatic calculation of tool positions, 5axis machining jobs can be programmed very easily.

5axis profile finishing

This feature enables the milling of flat or slightly curved surfaces. 5axis collision avoidance allows you to mill near steep walls using short tool lengths.

5axis z-level finishing

5axis z-level finishing is used to machine steep surfaces plane by plane or pocket by pocket. Flat areas can be automatically excluded.

5axis equidistant finishing

This method enables the machining of flat and steep areas in one operation. This strategy yields especially smooth transitions between individual toolpaths.

5axis rest machining

5axis rest machining offers all the options of 3D rest machining, plus 5axis tool positions, such as the machining of steep or flat areas only, groove milling or pencil milling.

5axis freepath machining

5axis freepath machining makes it possible to mill engravings reliably without collisions using short length tools, even near steep walls.

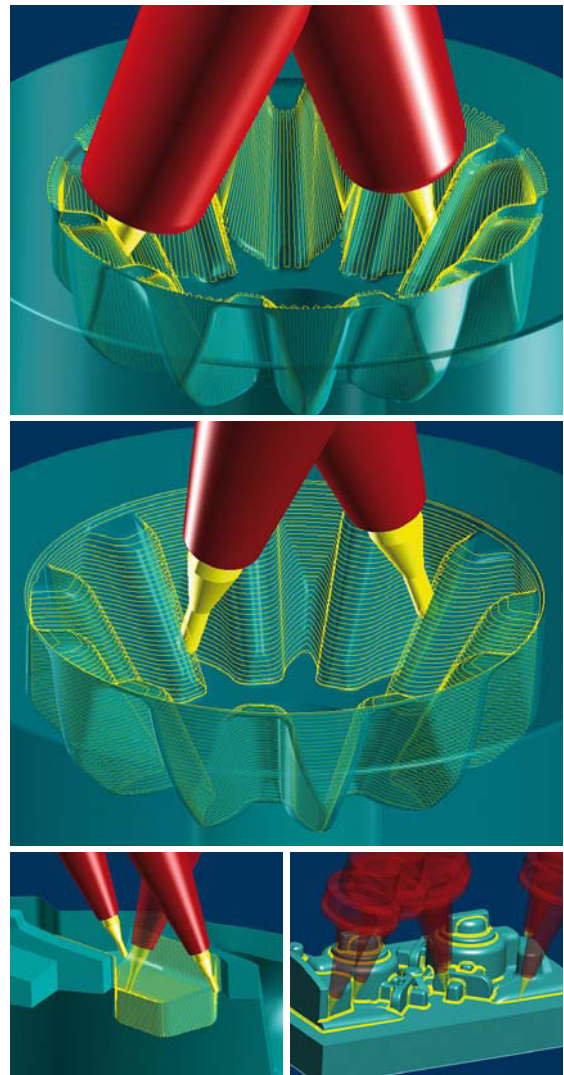

hyperMILL®

5AXIS

Stand-alone | hyperCAD® | Autodesk® Inventor® | SolidWorks®

5axis rework machining

This strategy transforms 3axis milling programs into 5axis milling programs. 3D and 5axis toolpaths can also be optimised to improve milling results.

5axis cutting edge

The strategy enables the precise and reproducible machining of 3D cutting tools.

5axis toolpath editing

The toolpath editing function enables the simple and convenient editing of job list-based toolpaths.

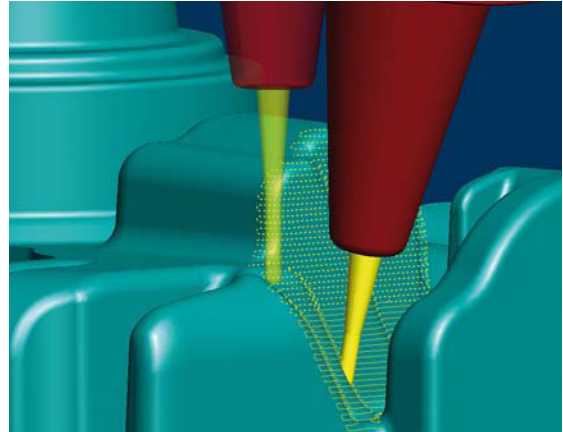

5axis automatic indexing (Mold & Die Advanced)

Automatic indexing 'automates' the programming of 3+2 milling and offers an alternative to 5axis simultaneous machining. This strategy calculates collision-free fixed tool angles for individual milling areas and/or toolpaths that can then be linked by means of a 5axis simultaneous movement. As a result, areas that require multiple tool angles for machining are programmed and milled in a single operation.



hyperMILL®

5AXIS

Stand-alone | hyperCAD® | Autodesk® Inventor® | SolidWorks®

Strategies for surface machining

Larger, slightly curved surfaces and geometries that follow leading surfaces or profiles can be milled very efficiently using 5axis machining.

5axis top milling and expanded top milling of surfaces

This strategy is used for the machining of large, moderately curved surfaces. Greater distances between paths result in reduced milling time. This strategy can also be used for 5axis roughing thanks to multiple infeed and stock detection.

5axis swarf cutting

This strategy is well-suited for the machining of walls and curved surfaces. When using swarf cutting, the workpiece surface is machined with the tool flank. Larger distances between paths ensure lower milling times and an improved workpiece surface quality.

5axis contour machining

5axis contour machining allows for milling grooves, scribing, engraving, deburring and trimming and chamfering. The fully automatic collision check makes programming these machining operations easy and reliable.

5axis shape offset roughing and finishing

This new 5axis machining strategy enables the simple, time saving programming of complex parts. Using this strategy, curved surfaces can be machined with a consistent offset.

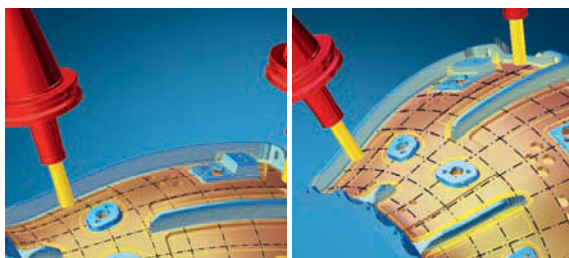
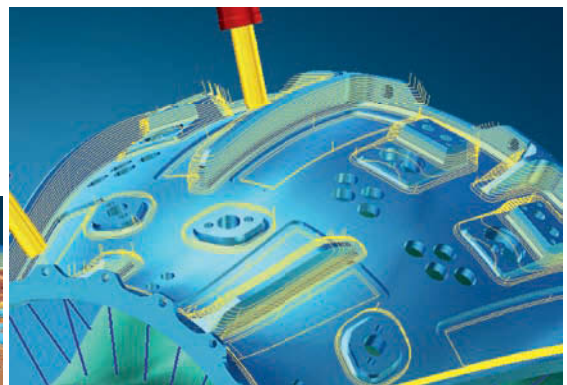
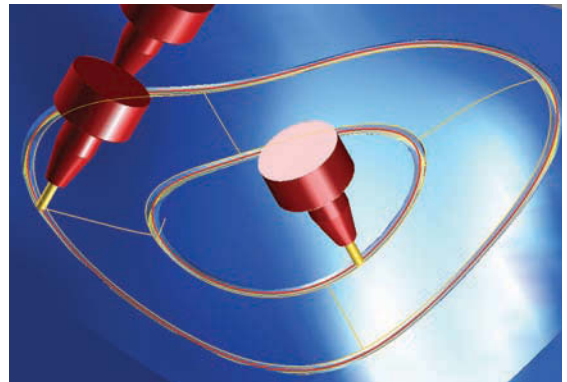
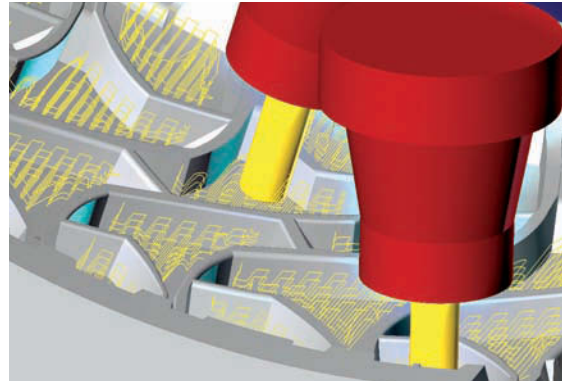

Simulation

The *hyperVIEW*® simulation software is a powerful control tool that delivers a precise overview of the generated milling paths. *hyperVIEW*® provides fast and dynamic simulations of all your tool movements before the final NC program is generated.

hyperMILL®'s machine and material removal simulation makes efficient workspace monitoring possible. A check is made using the stored machine model to see whether the machining job can be completed within the planned machine's workspace or whether limit switches will be traversed.

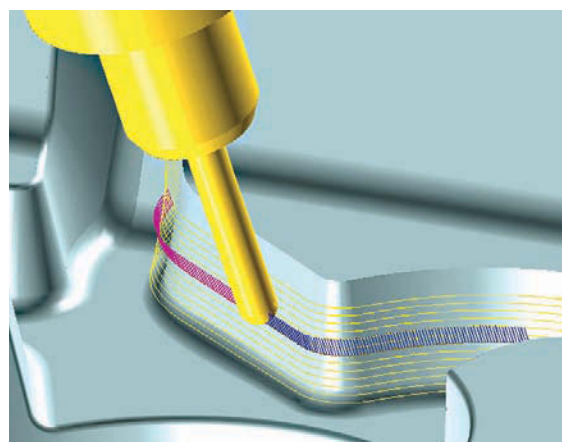

hyperMILL®

5AXIS

Stand-alone | hyperCAD® | Autodesk® Inventor® | SolidWorks®

The OPEN MIND tool database

Tools along with the tool number, geometry, holder and head can all be stored in a tool database. By systematically maintaining and expanding the tool database, users can build up a pool of data that will facilitate the fast and efficient use of tools in hyperMILL®.

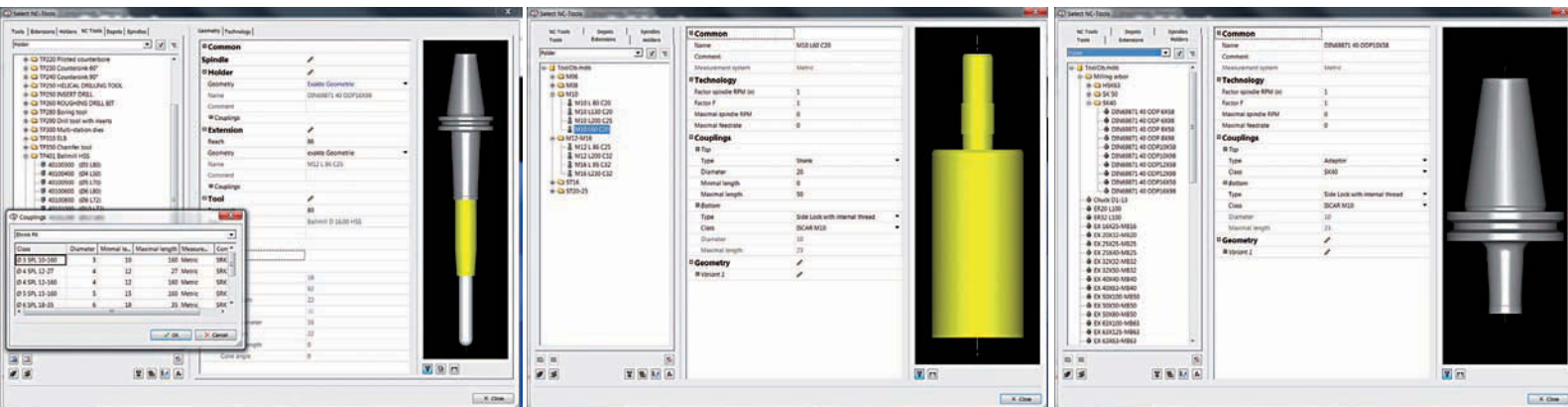

OPEN MIND post processors

hyperMILL® is able to calculate toolpaths independently of machine and controller. The post processor generates NC programs based on this neutral data. hyperMILL® 5AXIS is delivered with a custom post processor that is adjusted specifically to the machine, controller and materials used.

